

PRODUCT CATALOGUE

Vertical Pillow Bag Machines – PM Series



Stick-Pack



Pillow Bags



Sachet-Bags



Stand-Up Pouches

Side-Gusseted Bags

Machine Series: **PM** Box Motion

Vertical Pillow Bag Packaging Machine

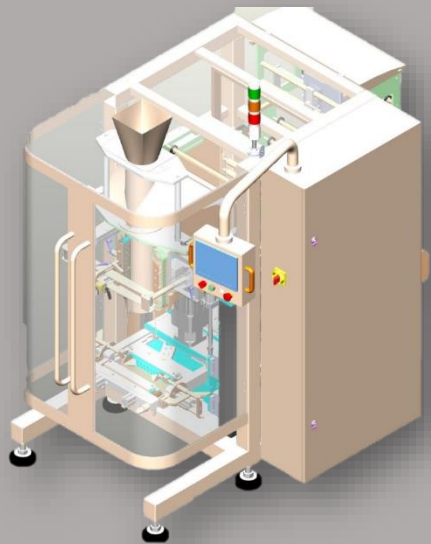

Applicable Bags:

Stand-Up Pouches



Stand-Up Pouches



Side-Gusseted Bags

Applicable Products:

The machines of the Box Motion series are the ideal packaging solution for

- Bulk goods
- Piece goods
- Small parts

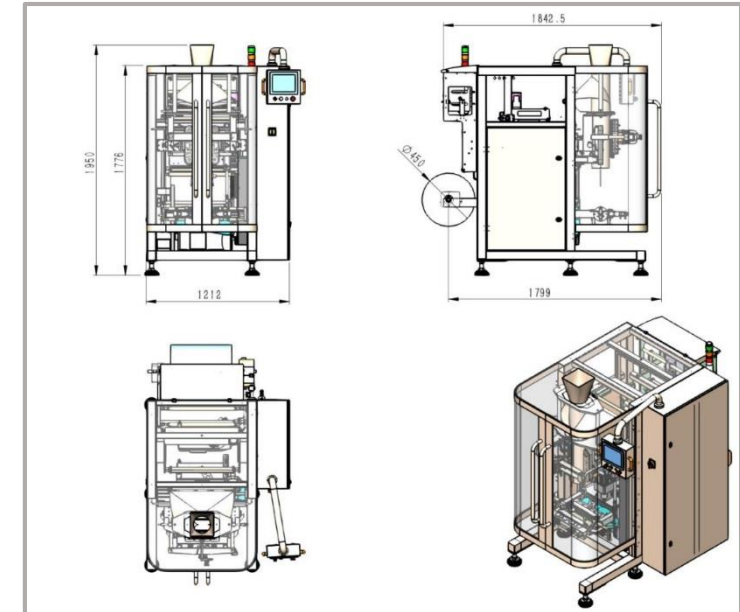

Machine Series: PM-100

Sachet forming, filling and sealing machine

Applicable Products:

The PM-100 series reliably and fail-safe packs the following products in sachet bags:

- Granules
- Powder
- Small parts
- Liquids



Sealing cycles:
up to 100 pieces / minute*

Applicable Bags:

4-side sealed bags:

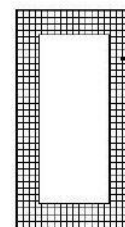

Net pattern with horizontal cut



Stripe pattern horizontal cut

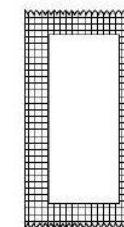

Net pattern with zig-zag cut

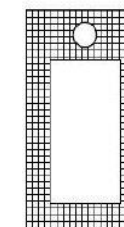

Net pattern with perforated central cutout

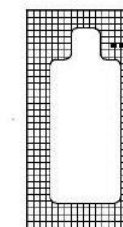

Specially shaped bag with net pattern

3-side sealed bags:

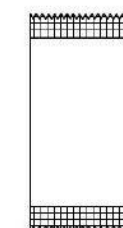

Model	Bag Width	Bag Length	Max. Filling Weight
PM-100G	Min. 80mm Max. 85mm	Min. 30mm Max. 120mm	Depending on bag format and dosing system
PM-100L	Min. 30mm Max. 85mm	Min. 30mm Max. 120mm	Depending on bag format and dosing system
PM-100P	Min. 30mm Max. 85mm	Min. 30mm Max. 120mm	Depending on bag format and dosing system
PM-100T	Min. 30mm Max. 85mm	Min. 30mm Max. 120mm	Depending on bag format and dosing system
PM-100V	Min. 30mm Max. 85mm	Min. 30mm Max. 120mm	Depending on bag format and dosing system

Machine Series: PM-150

Vertical Pillow Bag Machine

Applicable Bags:

4-side sealed pouch

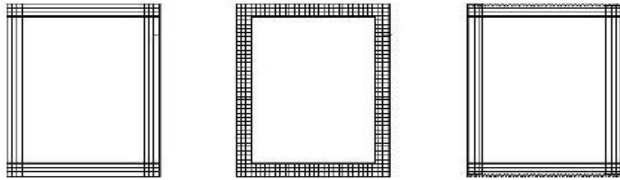

3-side sealed pouch

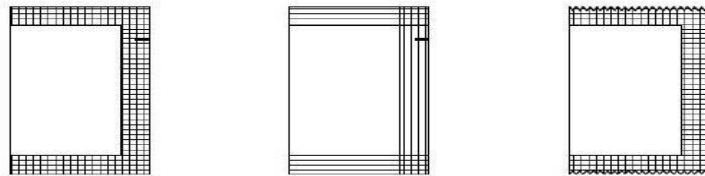

Backseal bag

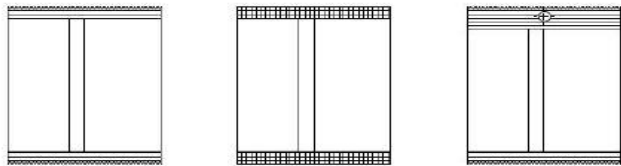

Triangular bag

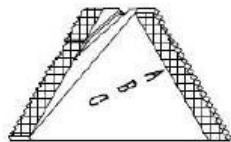

Applicable Products:

The PM-150 series quickly and safely packs the following products in pillow bags:

- Granules
- Powder
- Creams
- Liquids

Sealing cycles:
up to 60 pieces / minute



Model	Bag Width	Bag Length	Max. Filling Weight
PM-150B	Min. 30mm Max. 120mm	Min. 80mm Max. 190mm	Depending on bag format and dosing system
PM-150B3	Min. 30mm Max. 130mm	Max. 180mm	Depending on bag format and dosing system
PM-150B4	Min. 30mm Max. 130mm	Max. 180mm	Depending on bag format and dosing system
PM-150BT	Min. 30mm Max. 80mm	Min. 40mm Max- 100mm	Depending on bag format and dosing system

Machine Series: PM-180

Stick-Pack Bag Packaging Machine



Applicable Products:

With our PM-180 series the following products will be in safe hands:

- Granules
- Powder
- Creams
- Liquids

Sealing Cycles:
Up to 100 pieces/min



Applicable Bags:

Stick-Pack Bags

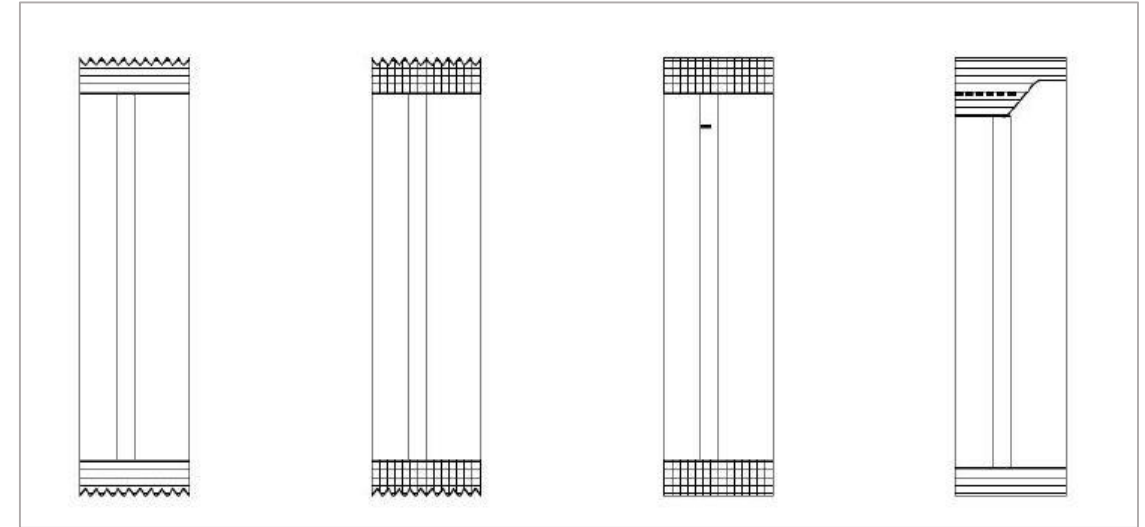

Stick-Packs with zig-zag cut

Stick-Packs with net pattern and zig-zag cut

Stick-Packs with net pattern and horizontal cut

Stick-Packs with spout perforation

Model	Bag Width	Bag Length	Max. Filling Weight
PM-180	Min. 16mm Max. 80mm	Min. 70mm Max. 180mm	Depending on bag format and dosing system
PM-180-2	Min. 16mm Max. 35x2mm	Min. 70mm Max. 180mm	Depending on bag format and dosing system
PM-180-H	Min. 16mm Max. 80mm	Min. 70mm Max. 240mm	Depending on bag format and dosing system
PM-180BIB	Min. 100mm Max. 150mm	Min. 120mm Max. 250mm	Depending on bag format and dosing system

Machine Series: PM-190

Stick-Pack Packaging Machine

Applicable Bags:

Stick-Pack Bags

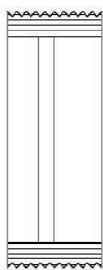

Stick-Pack with zig-zag cut



Stick-Pack with net pattern and zig-zag cut

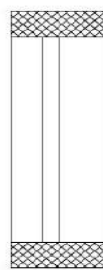

Stick-Pack with net pattern and horizontal cut



Stick-Packs with spout perforation

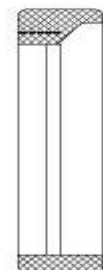

Stick-Packs with rounded corners



Specially shaped Stick-Packs



Applicable Products:

The following products can be packed with our PM-190 series:

- Granules
- Powder
- Creams
- Liquids

Sealing cycles:
Up to 100 pieces/min



Model	Bag Width	Bag Length	Max. Filling Weight
PM-190	Min. 16mm Max. 90mm	Min. 70mm Max. 200mm	Depending on bag format and dosing system
PM-190-2	Min. 16mm Max. 40x2mm	Min. 70mm Max. 200mm	Depending on bag format and dosing system
PM-190H	Min. 16mm Max. 90mm	Min. 70mm Max. 200mm	Depending on bag format and dosing system
PM-190H-2	Min. 14mm Max. 40x2mm	Min. 70mm Max. 200mm	Depending on bag format and dosing system

Machine Series: MLP

Multi-Lane Stick-Pack Packaging Machine

Applicable Products:

The following products can be packed with our MLP series:

- Granules
- Powder
- Creams
- Liquids



Sealing Cycles:
Up to 270 pieces/min



Applicable Bags:

Stick-Pack Bags

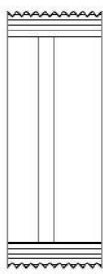

Stick-Pack with zig-zag cut



Stick-Pack with net pattern and zig-zag cut



Stick-Pack with net pattern and horizontal cut



Stick-Packs with spout perforation

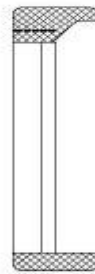

Stick-Packs with rounded corners



Specially shaped Stick-Packs

Model	Bag Width	Bag Length	Max. Filling Weight
MLP-800A-04	Min. 40mm Max. 95mm	Min. 70mm Max. 200mm	Depending on bag format and dosing system
MLP-800B-04	Min. 40mm Max. 95mm	Min. 70mm Max. 200mm	Depending on bag format and dosing system
MLP-800B-06	Min. 35mm Max. 60mm	Min. 70mm Max. 200mm	Depending on bag format and dosing system

Machine Series: PM-320

Pillow Bag Packaging Machine



Applicable Products:

With our PM-320 series the following products are in safe hands:

- Granules
- Powder
- Snacks
- Sweets

Sealing Cycles:
Up to 120 pieces/min

Pillow Bags / Sachet Bags

Applicable Bags:

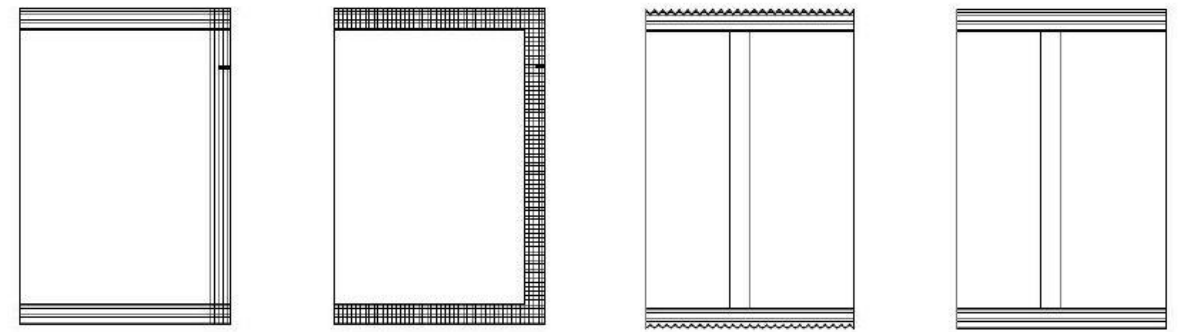

3-side sealed pouch

back-sealed bags



Model	Bag Width	Bag Length	Max. Filling Weight
PM-320BE	Min. 50mm Max. 150mm	Min. 80mm Max. 200mm	Depending on bag format and dosing system
PM-320B3	Min. 50mm Max. 160mm	Min. 80mm Max. 200mm	Depending on bag format and dosing system
PM-320E	Min. 50mm Max. 150mm	Min. 80mm Max. 200mm	Depending on bag format and dosing system
PM-320F	Max. 160mm	Max. 200mm	Depending on bag format and dosing system
PM-320F2	Max. 80x2mm	Max. 160mm	Depending on bag format and dosing system
PM-320F3	Max. 55x3mm	Max. 330mm	Depending on bag format and dosing system

Machine Series: PM-360

Vertical Pillow Bag Machine

Applicable Bags:

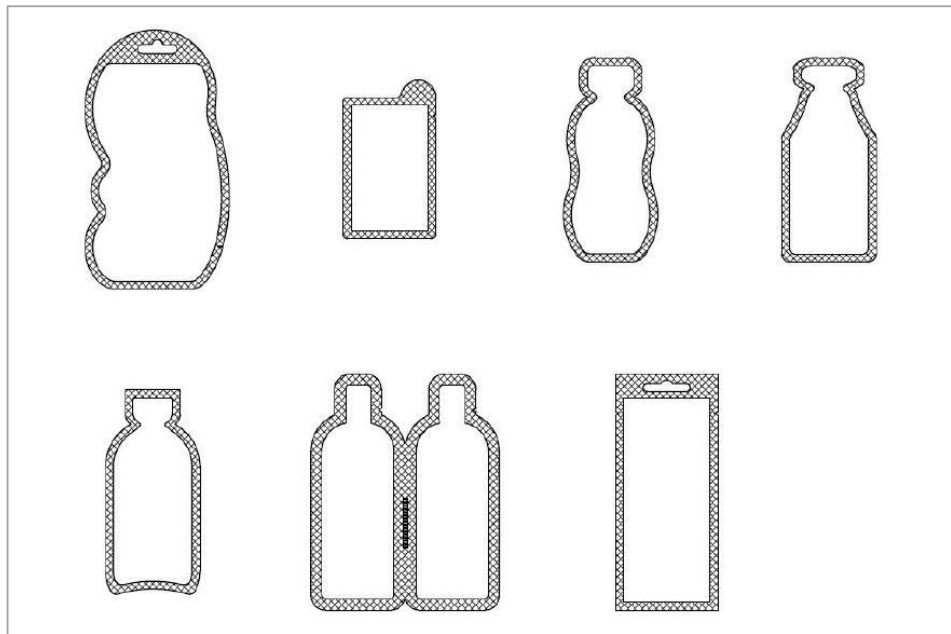

Applicable Products:

The following products can be packed with our PM-360 series:

- Powder
- Creams
- Cosmetic wipes
- Stickers



Sealing Cycles:
Up to 60 pieces/min

Model	Bag Width	Bag Length	Max. Filling Weight
PM-360S	Max. 160mm	Max. 160mm	Depending on bag format and dosing system
PM-360S2	Max. 80x2mm	Max. 160mm	Depending on bag format and dosing system

Machine Series: PM-420/620/720/1020

Vertical Pillow Bag Packaging Machine



Sealing Cycles:
Up to 45 pieces/min

Applicable Bags:

Stand-Up Pouches



Stand-Up Pouches



Side Gusseted Bags

Applicable Products:

The machines of the PM-420 series are the ideal packaging solution for

- Bulk materials
- Piece goods
- Small parts



Model	Bag Width	Bag Length	Max. Filling Weight
PM-420	Min. 80mm Max. 200mm	Min. 20mm Max. 300mm	Depending on bag format and dosing system
PM-620	Min. 110mm Max. 300mm	Min. 120mm Max. 600mm	Depending on bag format and dosing system
PM-720	Min. 180mm Max. 350mm	Min. 170mm Max. 700mm	Depending on bag format and dosing system
PM-1020	Min. 200mm Max. 500mm	Min. 200mm Max. 400mm	Depending on bag format and dosing system

Machine Series: APPB-350

Vertical pillow bag machine with tubular film



Sealing Cycles:
Up to 15 pieces/min

Model	Bag Width	Bag Length	Max. Filling Weight
APPB-350	Min. 70mm Max. 350mm	Min. 70mm Max. 500mm	Abhängig von Beutelformat und Dosiersystem
APPB-350L	Min. 70mm Max. 500mm	Min. 70mm Max. 550mm	Abhängig von Beutelformat und Dosiersystem

Applicable Bags:

- PE pillow bags on a roll
- PE side gusseted bags on a roll

Applicable Products:

With our APPB-350 series these products can be packed in tubular film or pillow bags from the roll:

- Small parts (screws, dowels)
- Bulk material
- Piece goods

Machine specifications:

- Processes both tubular film and pillow bags on a roll
- Can be integrated into almost any packaging line
- Fast operation and high reliability
- Simple film change
- User-friendly touch-screen
- Bag lengths freely selectable in the menu



Machine Series: AP-KZ-1-2 / AP-KS-N95

Mask Making Machines



**Production Speed:
Up to 110 pcs / min**

Applicable Material:

The following products can be processed on our mask making machines:

- Sponges made of composite fibres (filter paper)
- Activated carbon cloths
- Spunbonded cloths
- Hot air wipes

Types of protective face masks

Face Masks



FFP2 respiratory protection masks



Disposable face masks

Specifications	AP-KZ-1-2	AP-KS-N95
Mask dimensions:	175 (L) x 95 (W) mm	160 (L) x 105 (W) mm
Production speed:	90-110 pcs/min	40-45 pcs/min
Material:	Non-woven, Composite fibre sponge (Filter paper), Activated carbon cloth	Spun bond cloth, Melt blown cloth, Hot air cloth
Layers:	3 layers	3 / 6 layers
Welding method:	Ultrasonic welding	Ultrasonic welding
Operation screen:	7" touch screen	7" touch screen
Power:	8.5 kW	15.5 kW
Voltage:	220 V / 1PH, 50Hz	380 V / 3PH, 50Hz
Machine dimensions:	6700 (L) x 3600 (W) x 2000 (H) mm	10000 (L) x 1500 (W) x 2110 (H) mm
Air pressure / consumption:	0.5-0.7 Mpa / 300L/min	0.5-0.7 Mpa / 380L/min

Additional Options: PM-Series

Handling:

- Customized filling hoppers
- Product-adapted sorting tables
- Operation by foot switch

Punching tools:

- Euro punching
- Round perforation

Dosing units:

- Linear scales
- Multi-head weighers
- Vibratory conveyor heads
- Auger filler
- Volume dosing unit

Possible forming shoulders:

- Stand-up pouch
- Side gusseted bags

Printed films:

- Print mark control

Printing and embossing units:

- Individual labelling systems
- Printing unit and label dispenser
- Hot stamping systems / printers
- Thermal transfer printer

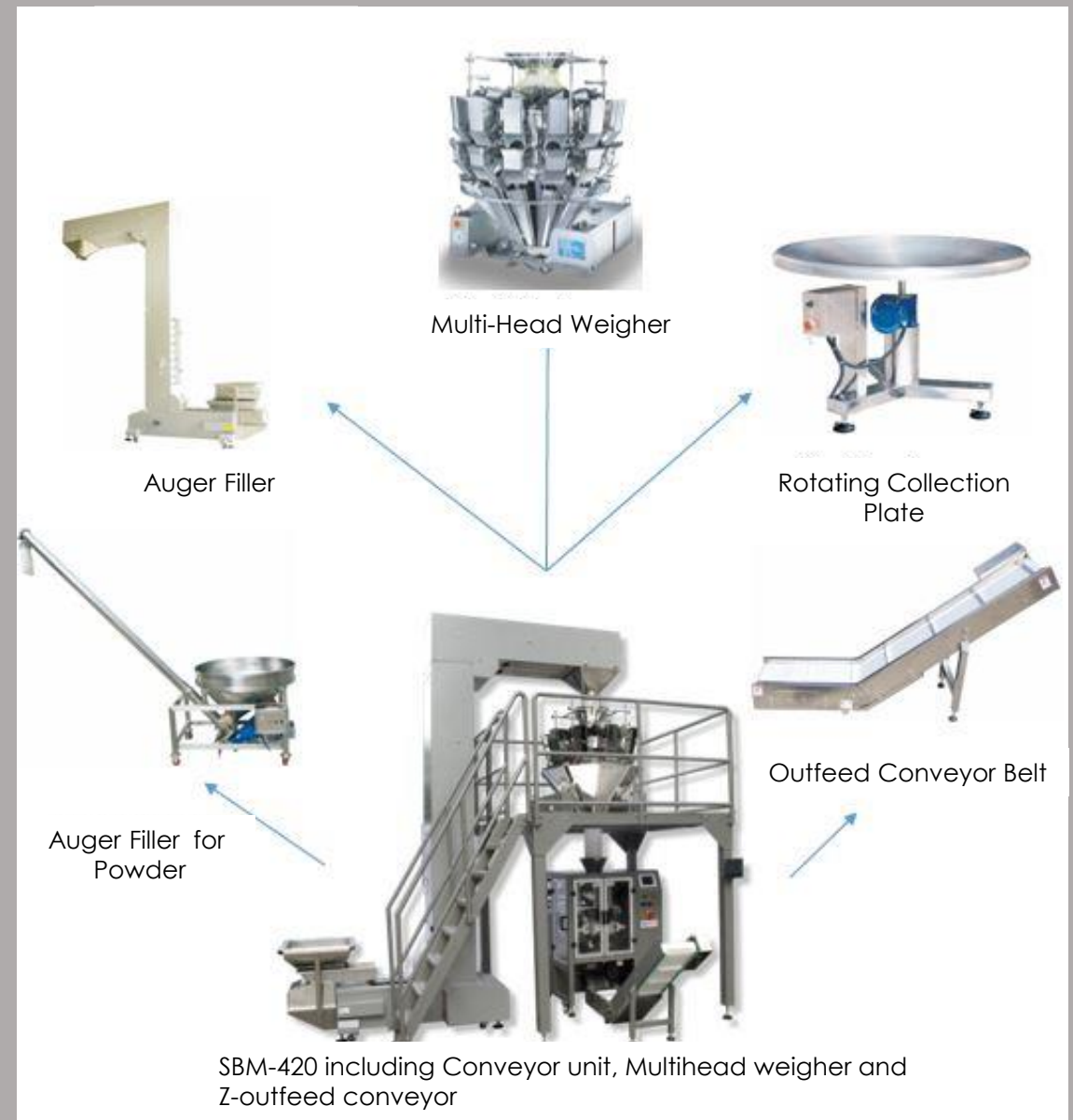

About alpha-pack GmbH

With decades of experience, the **family-owned manufacturing companies** of Alpha-Pack Group GmbH rank among the pioneers in the packaging industry - We live innovation and progress. Unique to the market, we offer system solutions for the integrated packaging process in our corporate group, including suitable consumables - **Everything from one single source without intermediate trade.**

Thanks to our **many years of experience**, we are experts in developing, producing and selling packaging machines. Since our foundation, we have been dedicating ourselves to the development and introduction of **advanced equipment and technologies..** Due to the expansion of our mature and international brand and distribution network, our packaging machines have so far been exported to **more than 50 countries and regions.**

alpha-pack GmbH – smart packaging solutions by manufacturers

* The output quantities per minute are average values, depending on film type and thickness, product dimensions and machine handling. It is not possible to combine all maximum dimensions. We reserve the right to make technical changes or changed output values exclusively.

smart packaging solutions by manufacturers



For further questions about our packaging machines and services, please contact us at:

alpha-pack GmbH
Otto-Hahn-Allee 1
50374 Erftstadt

+49 2235-79479-0

info@alphapack.de

www.alphapack.de