

Machine Series: AHP

Horizontal Pillow Bag Machine – Film feeding from the top

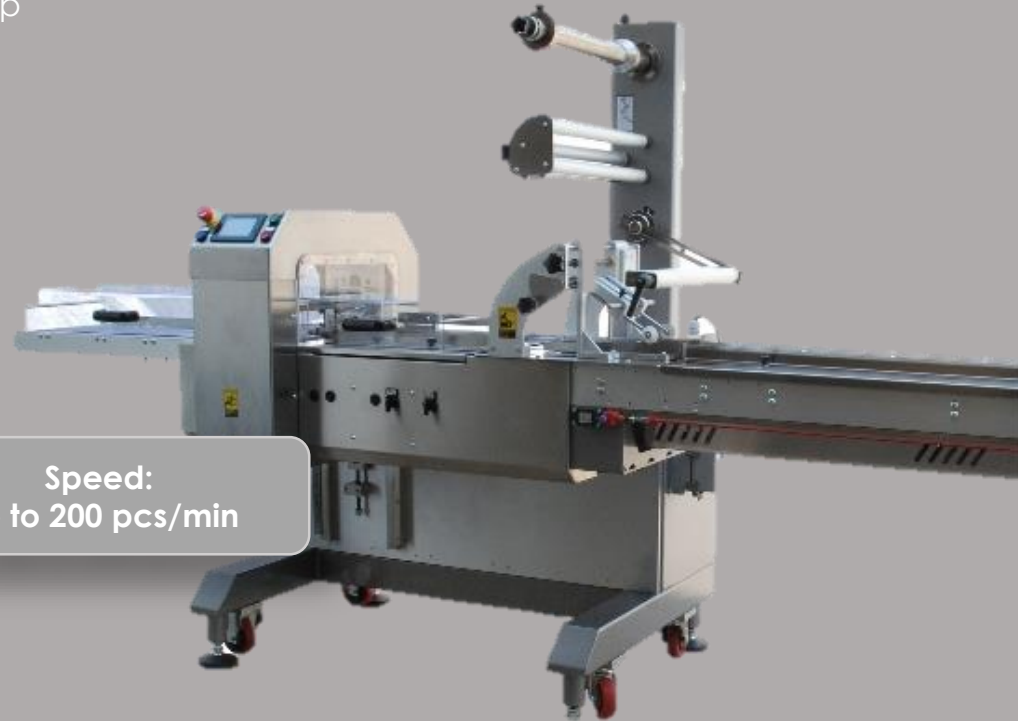

**Speed:
Up to 200 pcs/min**

Technical Details:

- Steel frame / stainless steel construction
- Products are transported by gripper loading
- Teflon-coated, permanently heated sealing stamps
- Simple touchscreen operation via color symbols
- Continuous feeding of the products by photocell control
- Safety protection covers / alarm signal lamp
- 3-sided sealed seam packaging (fin seam)

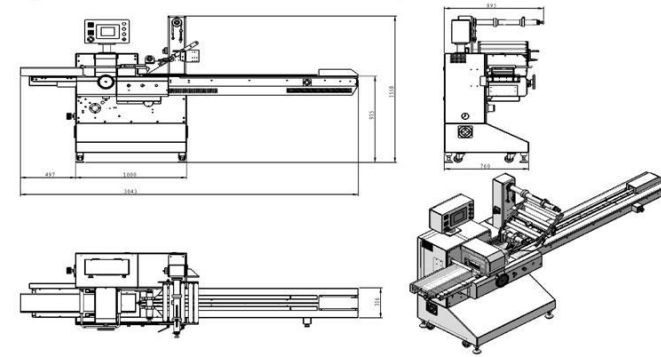

Machine Dimensions

Applicable Products:

Our AHP series (film from above) reliably packages among others the following products:

- Medical Products
- Fruit and Vegetables
- Technology
- Biscuits
- Frozen food

Model	AHP-400-1S	AHP-450-3S	AHP-450-3S mini	AHP-500-3S	AHP-600-3S
Applicable Films:	PP / POF / Composite Films	PP / POF / Composite Films	PP / POF / Composite Films	PP / POF / Composite Films	PP / POF / Composite Films
Speed:	UT 100 pcs/min	UT 90 pcs/min	UT 90 pcs/min	UT 200 pcs/min	UT 150 pcs/min
Sealing Mechanism 1 & 2:	longitudinal/rotation	Longitudinal/rotation /3 servomotors	Longitudinal/rotation /3 servomotors	Longitudinal/rotation /3 servomotors	Longitudinal/rotation /3 servomotors
Max. Product Height:	100 mm*	-	-	120 mm*	140 mm*
Max. Product Width:	200 mm*	-	-	250 mm*	300 mm*
Product Length:	40-550 mm*	Up to 600 mm*	Up to 400 mm*	60-550 mm*	70-550 mm*
Max. Roll Size:	400 x Ø 350 mm	450 x Ø 300 mm	450 x Ø 300 mm	500 x Ø 350 mm	600 x Ø 350 mm
Max. Connected Load:	2,5 kW	3,0 kW	3,0 kW	3,0 kW	3,5 kW
Air Pressure (dry air):	6,0 bar	6,0 bar	6,0 bar	6,0 bar	6,0 bar
Supply Voltage:	400 V / 3-phases	400 V / 3-phases	400 V / 3-phases	400 V / 3-phases	400 V / 3-phases